

Elettropompa NMT1220R - 610004

Motorpump NMT1220R - 610004

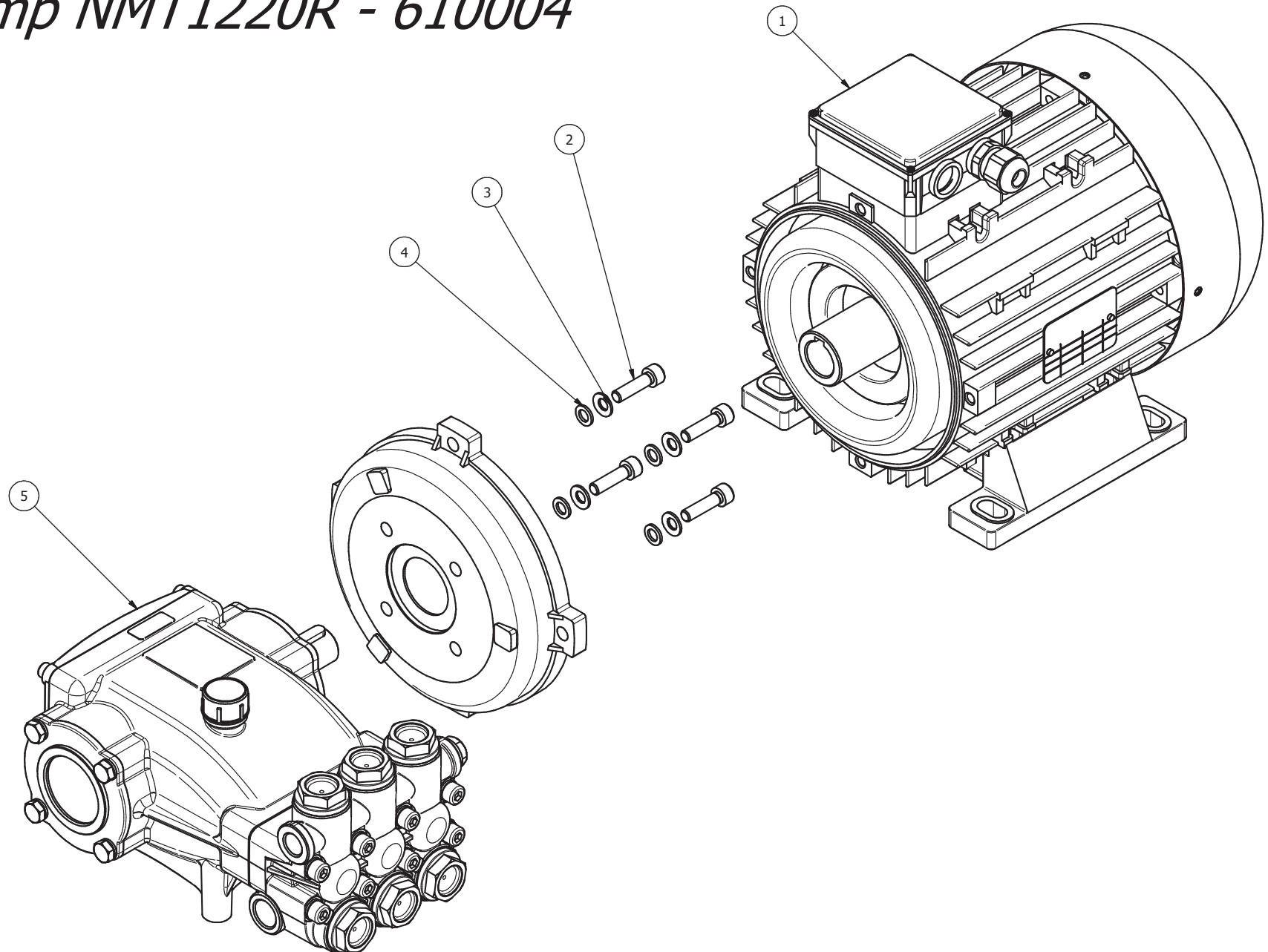

ELETTROPOMPA NMT1220R - 610004 / MOTORPUMP NMT1220R - 610004

PRESSIONE MASSIMA / *MAX PRESSURE* : 200 BAR

PORTATA A 1450 RPM / *FLOW RATE AT 1450 RPM* : 12.5 l/min

PORTATA A 1740 RPM / *FLOW RATE AT 1740 RPM* : 15 l/min

POTENZA MASSIMA A 1450 RPM / *MAX POWER AT 1450 RPM* : 5.5 kW

POTENZA MASSIMA A 1740 RPM / *MAX POWER AT 1740 RPM* : 6.6 kW

PESO / *WEIGHT* : 42 kg

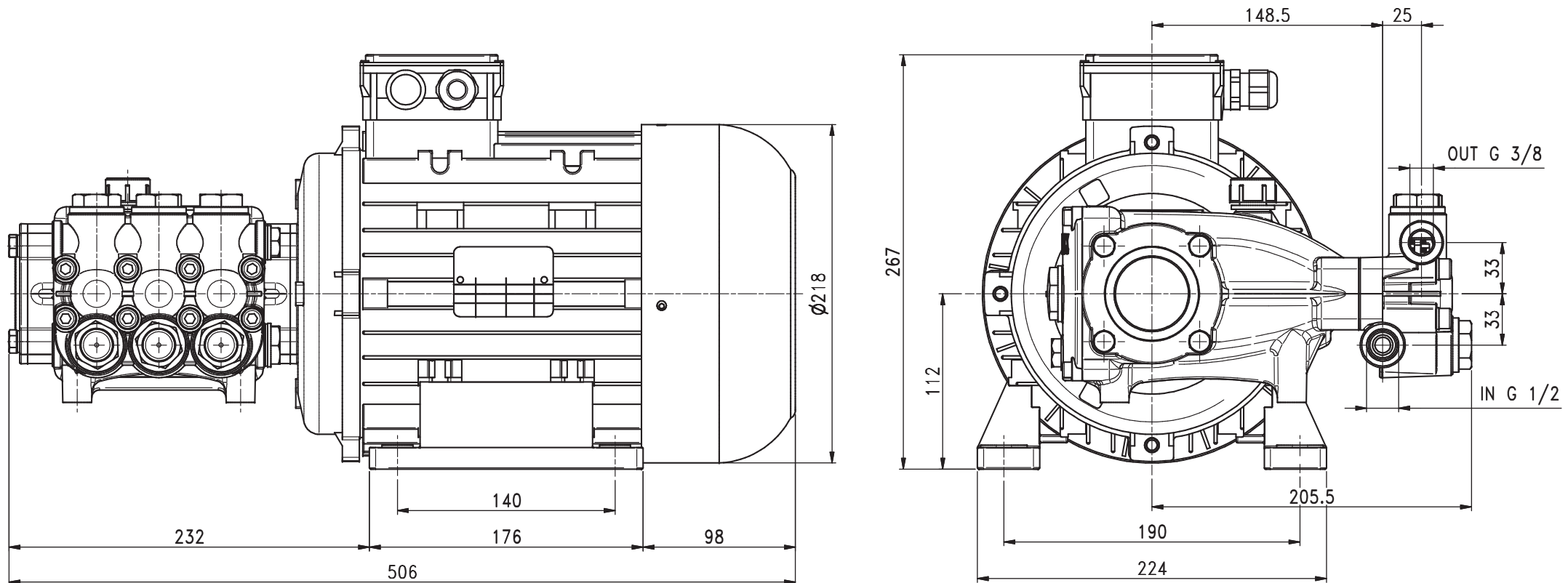

ELETTROPOMPA NMT1220R - 610004 MOTORPUMP**PARTS LIST****LISTA PARTI**

<i>Pos. Item</i>	<i>Codice Part Number</i>	<i>Description</i>	<i>Descrizione</i>	<i>Q.tà Q.ty</i>
1	5800.01	Electric Motor	<i>Motore Elettrico</i>	1
2	1801.08	Screw M8x30	<i>Vite TCEI M8x30</i>	4
3	1401.03	Spring washer Ø8	<i>Rosetta elastica Ø8</i>	4
4	1400.01	Washer Ø8.5	<i>Rosetta Ø8.5</i>	4
5	NMT1220R	Pump	<i>Pompa</i>	1

Elettropompa NMT1520R - 610005

Motorpump NMT1520R - 610005

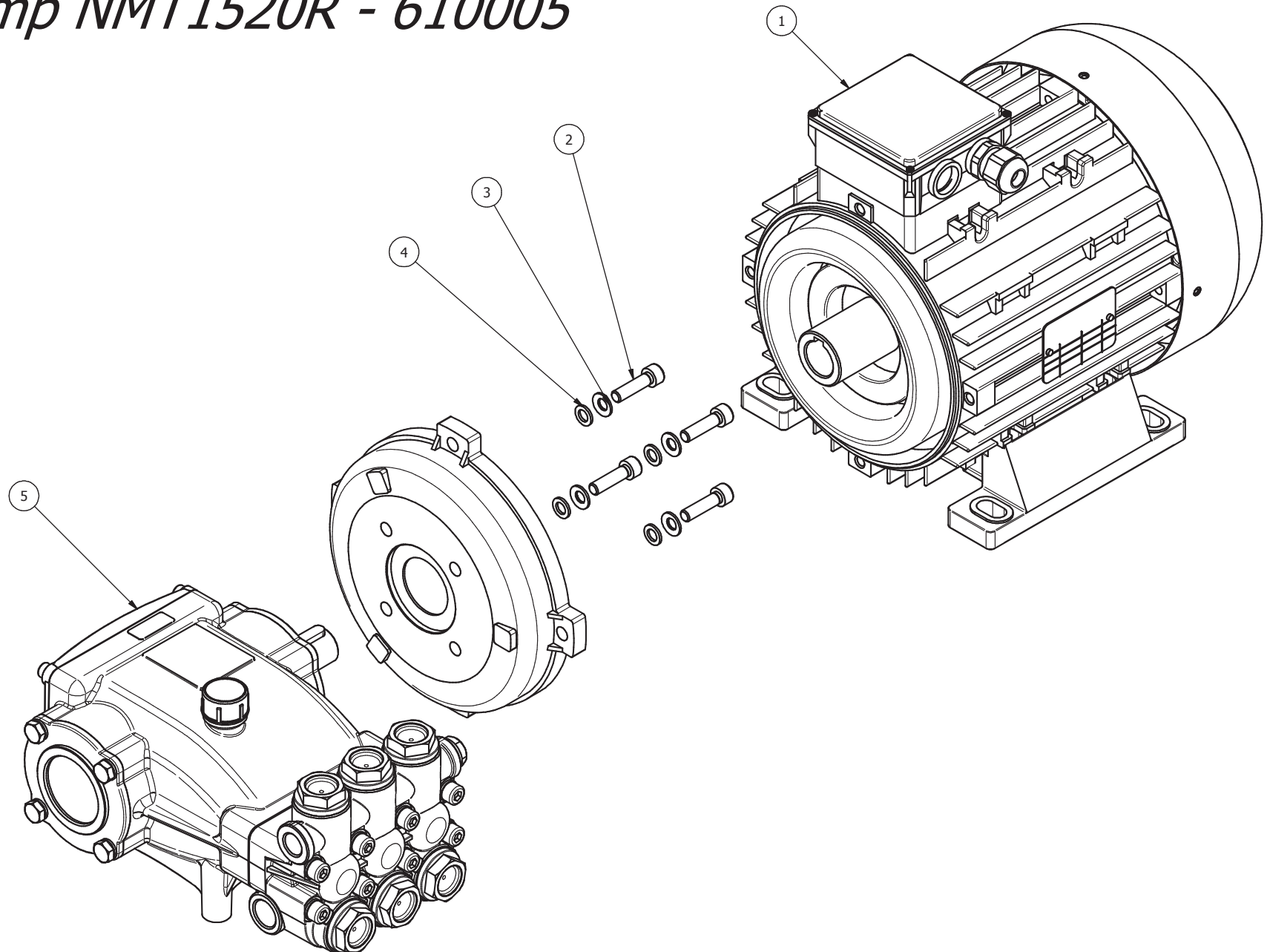

ELETTROPOMPA NMT1520R - 610005 / MOTORPUMP NMT1520R - 610005

PRESSIONE MASSIMA / *MAX PRESSURE* : 190 BAR

PORTATA A 1450 RPM / *FLOW RATE AT 1450 RPM* : 15 l/min

PORTATA A 1740 RPM / *FLOW RATE AT 1740 RPM* : 18 l/min

POTENZA MASSIMA A 1450 RPM / *MAX POWER AT 1450 RPM* : 5.5 kW

POTENZA MASSIMA A 1740 RPM / *MAX POWER AT 1740 RPM* : 6.6 kW

PESO / *WEIGHT* : 42 kg

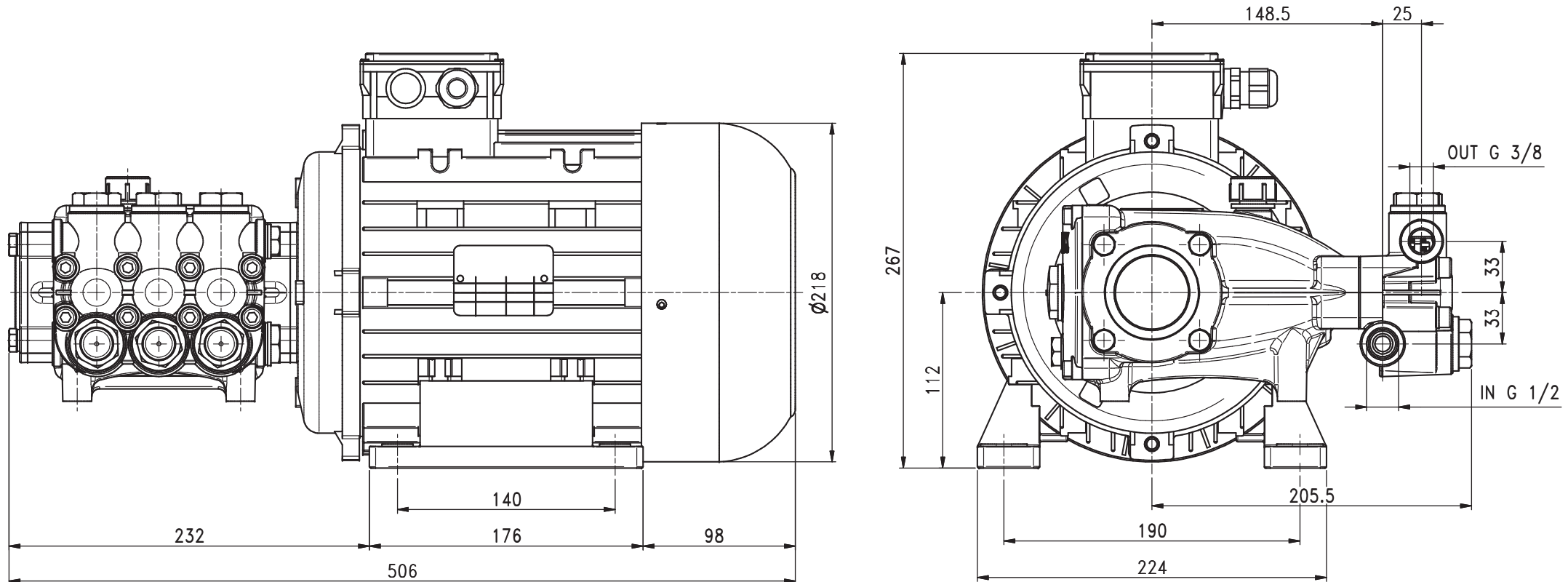

ELETTROPOMPA NMT1520R - 610005 MOTORPUMP**PARTS LIST****LISTA PARTI**

<i>Pos. Item</i>	<i>Codice Part Number</i>	<i>Description</i>	<i>Descrizione</i>	<i>Q.tà Q.ty</i>
1	5800.01	Electric Motor	<i>Motore Elettrico</i>	1
2	1801.08	Screw M8x30	<i>Vite TCEI M8x30</i>	4
3	1401.03	Spring washer Ø8	<i>Rosetta elastica Ø8</i>	4
4	1400.01	Washer Ø8.5	<i>Rosetta Ø8.5</i>	4
5	NMT1520R	Pump	<i>Pompa</i>	1

Elettropompa NMT2120R - 610006

Motorpump NMT2120R - 610006

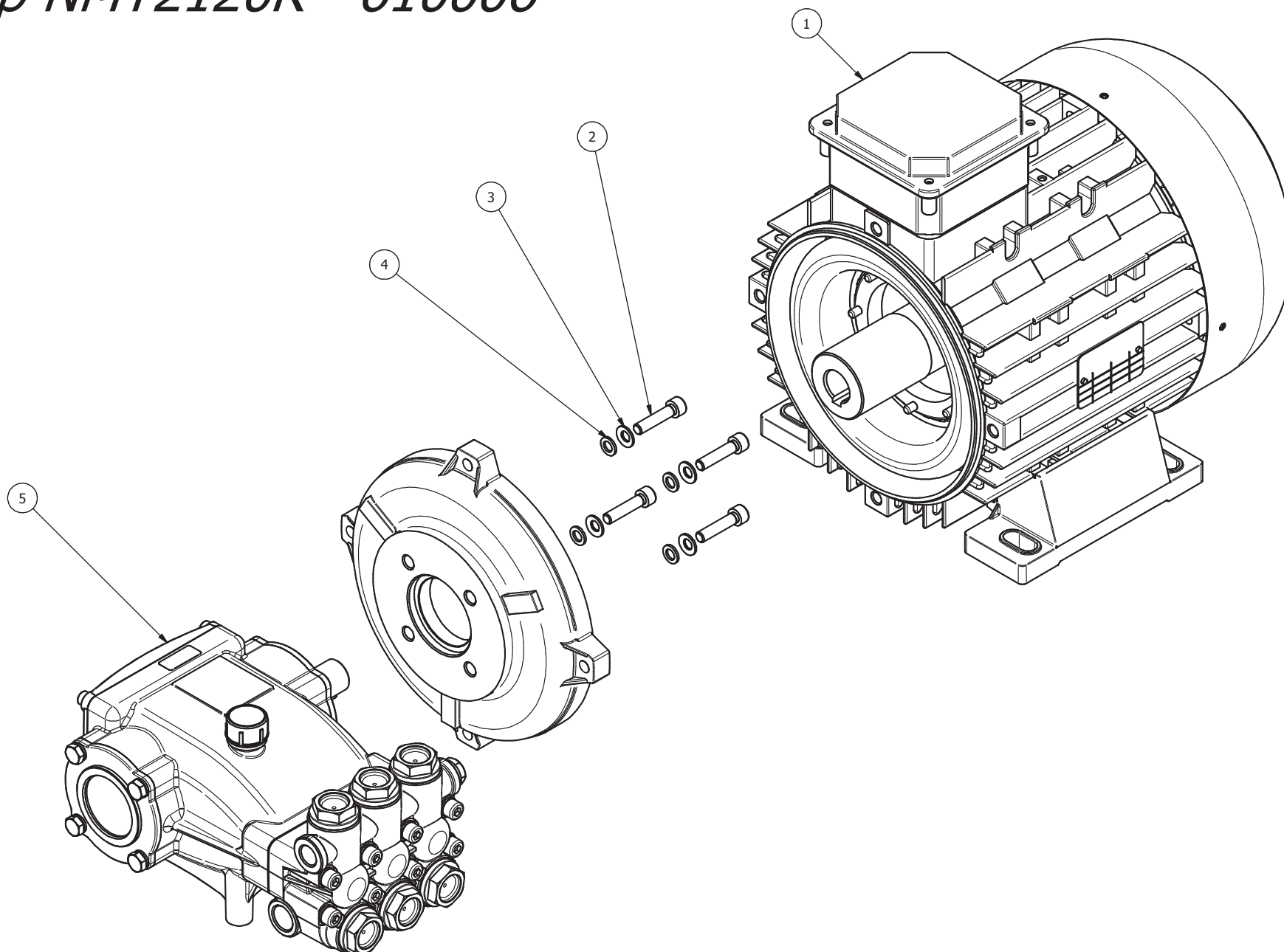

ELETTROPOMPA NMT2120R - 610006 / MOTORPUMP NMT2120R - 610006

PRESSIONE MASSIMA / *MAX PRESSURE* : 190 BAR

PORTATA A 1450 RPM / *FLOW RATE AT 1450 RPM* : 21 l/min

PORTATA A 1740 RPM / *FLOW RATE AT 1740 RPM* : 25 l/min

POTENZA MASSIMA A 1450 RPM / *MAX POWER AT 1450 RPM* : 7.5 kW

POTENZA MASSIMA A 1740 RPM / *MAX POWER AT 1740 RPM* : 9 kW

PESO / *WEIGHT* : 58 kg

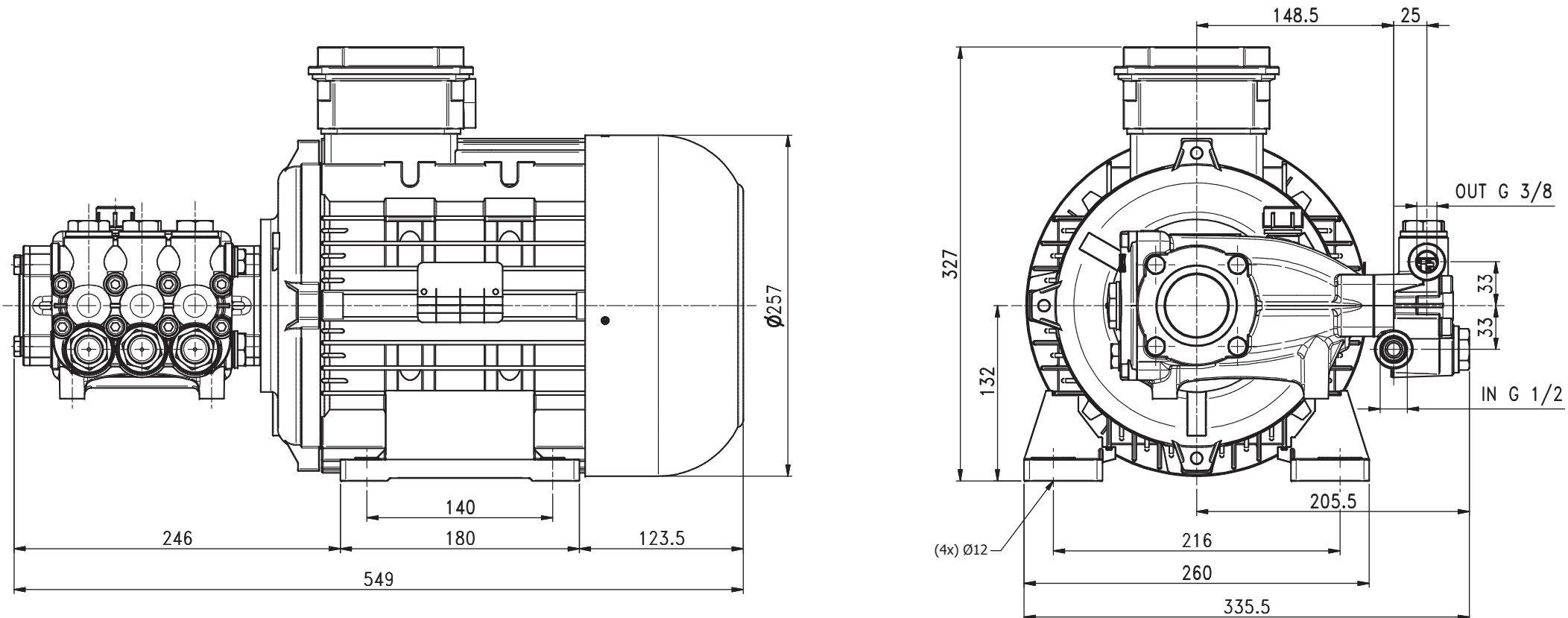

ELETTROPOMPA NMT2120R - 610006 MOTORPUMP**PARTS LIST****LISTA PARTI**

<i>Pos. Item</i>	<i>Codice Part Number</i>	<i>Description</i>	<i>Descrizione</i>	<i>Q.tà Q.ty</i>
1	5800.11	Electric Motor	<i>Motore Elettrico</i>	1
2	1801.01	Screw M8x35	<i>Vite TCEI M8x35</i>	4
3	1401.03	Spring washer Ø8	<i>Rosetta elastica Ø8</i>	4
4	1400.01	Washer Ø8.5	<i>Rosetta Ø8.5</i>	4
5	NMT2120R	Pump	<i>Pompa</i>	1